

34mm Half Bridge IGBT Module

$V_{CES}=1200V$, $I_{C\ nom}=100A$ / $I_{CRM}=200A$

Features :

- 1200V Trench / Field Stop process
- Low switching losses
- V_{cesat} has a positive temperature coefficient

Applications:

- Inverter welding machine

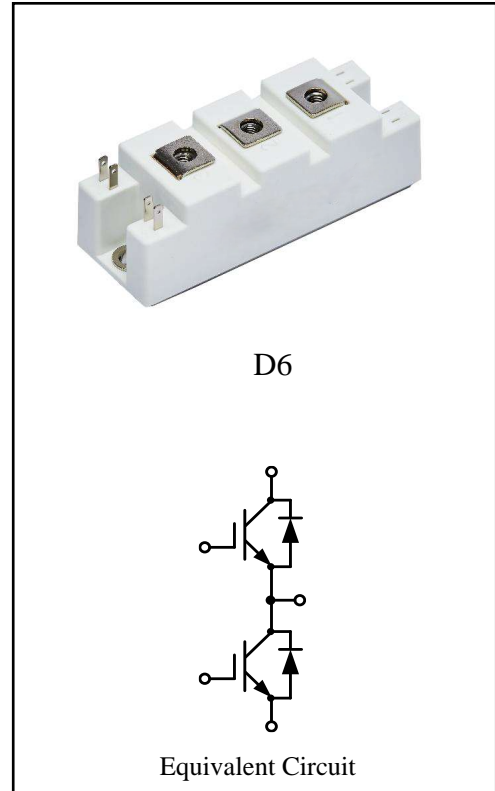

IGBT, Inverter

Maximum Ratings

Parameter	Conditions	Symbol	Value	Unit
Collector-Emitter voltage	$T_{vj}=25^{\circ}C$	V_{CES}	1200	V
Continuous DC collector current	$T_C=100^{\circ}C$, $T_{vj\ max}=175^{\circ}C$	$I_{C\ nom}$	100	A
Repetitive peak collector current	$t_p=1\ ms$	I_{CRM}	200	A
Gate emitter voltage		V_{GE}	± 20	V

Characteristic Values

Parameter	Conditions	Symbol	Value			Unit
			Min.	Typ.	Max.	
Collector-Emitter saturation voltage	$V_{GE}=15V, I_C=100A$ $V_{GE}=15V, I_C=100A$ $V_{GE}=15V, I_C=100A$	$T_{vj}=25^{\circ}C$ $T_{vj}=125^{\circ}C$ $T_{vj}=150^{\circ}C$	V_{CEsat}	1.98 2.25 2.32	2.50	V
Gate-Emitter threshold voltage	$I_C = 3.8mA, V_{GE}= V_{CE}$	$T_{vj}=25^{\circ}C$	$V_{GE(th)}$	4.80	5.80	6.40
Gate charge	$V_{GE}=-15V...+15V$		Q_G	0.49		μC
Internal gate resistor	$T_{vj}=25^{\circ}C$		R_{Gint}	7.83		Ω
Input capacitance	$f=100KHz, V_{CE}=25V, V_{GE}=0V$	$T_{vj}=25^{\circ}C$	C_{ies}	6.02		nF
Reverse transfer capacitance			C_{res}	0.25		
Collector-emitter cut-off current	$V_{CE}=1200V, V_{GE}=0V$	$T_{vj}=25^{\circ}C$	I_{CES}		1	mA
Gate-emitter leakage current	$V_{CE}=0V, V_{GE}=20V$	$T_{vj}=25^{\circ}C$	I_{GES}		100	nA
Turn-on delay time	$I_C=30A, V_{CE}=600V$ $V_{GE}=\pm 15V, R_G=10\Omega$ (inductive load)	$T_{vj}=25^{\circ}C$ $T_{vj}=125^{\circ}C$ $T_{vj}=150^{\circ}C$	t_{don}	152.6 167.7 176.6		ns
Rise time	$I_C=30A, V_{CE}=600V$ $V_{GE}=\pm 15V, R_G=10\Omega$ (inductive load)	$T_{vj}=25^{\circ}C$ $T_{vj}=125^{\circ}C$ $T_{vj}=150^{\circ}C$	t_r	32.3 34.2 31.2		
Turn-off delay time	$I_C=30A, V_{CE}=600V$ $V_{GE}=\pm 15V, R_G=10\Omega$ (inductive load)	$T_{vj}=25^{\circ}C$ $T_{vj}=125^{\circ}C$ $T_{vj}=150^{\circ}C$	t_{doff}	312.5 409.6 441.1		
Fall time	$I_C=30A, V_{CE}=600V$ $V_{GE}=\pm 15V, R_G=10\Omega$ (inductive load)	$T_{vj}=25^{\circ}C$ $T_{vj}=125^{\circ}C$ $T_{vj}=150^{\circ}C$	t_f	66.2 93.4 130.9		
Turn-on energy loss per pulse	$I_C=30A, V_{CE}=600V$ $V_{GE}=\pm 15V, R_G=10\Omega$ $di/dt = 700A/\mu s$ ($T_{vj} = 150^{\circ}C$) (inductive load)	$T_{vj}=25^{\circ}C$ $T_{vj}=125^{\circ}C$ $T_{vj}=150^{\circ}C$	E_{on}	1.43 2.27 2.71		
Turn-off energy loss per pulse	$I_C=30A, V_{CE}=600V$ $V_{GE}=\pm 15V, R_G=10\Omega$ $dv/dt=3000V/\mu s$ ($T_{vj} = 150^{\circ}C$) (inductive load)	$T_{vj}=25^{\circ}C$ $T_{vj}=125^{\circ}C$ $T_{vj}=150^{\circ}C$	E_{off}	1.11 1.85 2.10		mJ
SC data	$V_{GE}\leq 15V, V_{CC}=800V$ $V_{CEmax}=V_{CES}-L_{sCE}\cdot di/dt$ $t_p\leq 10\mu s, T_{vj}=150^{\circ}C$		I_{sc}	448		A
Temperature under switching conditions			$T_{vj op}$	-40	150	$^{\circ}C$

Diode, Inverter

Maximum Ratings

Parameter	Conditions	Symbol	Value	Unit
Repetitive peak reverse voltage	$T_{vj}=25^{\circ}\text{C}$	V_{RRM}	1200	V
Continuous DC forward current		I_F	30	A
Repetitive peak forward current	$t_p=1\text{ms}$	I_{FRM}	60	A
I^2t -value	$t_p=10\text{ms}$, $\sin 180^{\circ}$, $T_{vj}=125^{\circ}\text{C}$	I^2t	490	A^2s

Characteristic Values

Parameter	Conditions	Symbol	Value			Unit
			Min.	Typ.	Max.	
Forward voltage	$I_F=30\text{A}$, $V_{GE}=0\text{V}$ $T_{vj}=25^{\circ}\text{C}$	V_F		1.91	2.60	V
	$I_F=30\text{A}$, $V_{GE}=0\text{V}$ $T_{vj}=125^{\circ}\text{C}$		1.60			
	$I_F=30\text{A}$, $V_{GE}=0\text{V}$ $T_{vj}=150^{\circ}\text{C}$		1.50			
Peak reverse recovery current	$I_F=30\text{A}$, $-\text{di}_F/\text{dt}=700\text{A}/\mu\text{s}(T_{vj}=150^{\circ}\text{C})$ $V_R=600\text{V}$, $V_{GE}=-15\text{V}$ $T_{vj}=25^{\circ}\text{C}$	I_{RM}		53.8		A
	$T_{vj}=125^{\circ}\text{C}$		73.9			
	$T_{vj}=150^{\circ}\text{C}$		78.7			
Recovered charge	$I_F=30\text{A}$, $-\text{di}_F/\text{dt}=700\text{A}/\mu\text{s}(T_{vj}=150^{\circ}\text{C})$ $V_R=600\text{V}$, $V_{GE}=-15\text{V}$ $T_{vj}=25^{\circ}\text{C}$	Q_r		2.09		μC
	$T_{vj}=125^{\circ}\text{C}$		4.65			
	$T_{vj}=150^{\circ}\text{C}$		6.19			
Reverse recovered energy	$I_F=30\text{A}$, $-\text{di}_F/\text{dt}=700\text{A}/\mu\text{s}(T_{vj}=150^{\circ}\text{C})$ $V_R=600\text{V}$, $V_{GE}=-15\text{V}$ $T_{vj}=25^{\circ}\text{C}$	E_{rec}		0.61		mJ
	$T_{vj}=125^{\circ}\text{C}$		1.48			
	$T_{vj}=150^{\circ}\text{C}$		2.09			
Temperature under switching conditions		$T_{vj\text{ op}}$	-40		150	$^{\circ}\text{C}$

Module

Parameter	Conditions	Symbol	Value			Unit
Isolation test voltage	RMS, $f=50\text{Hz}$, $t=1\text{min}$	V_{ISOL}	4000			V
Internal isolation			Al_2O_3			
Storage temperature		T_{stg}	-40		125	$^{\circ}\text{C}$
Mounting torque for modul mounting		M	3.0		5.0	Nm
Terminal Connection Torque		M	2.5		5.0	Nm
Weight		W	155			g

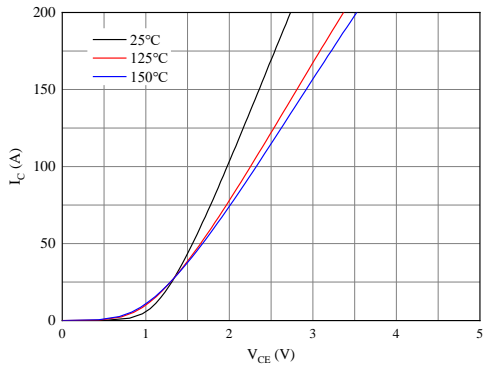

Fig 1. Typical output characteristics ($V_{GE}=15V$)

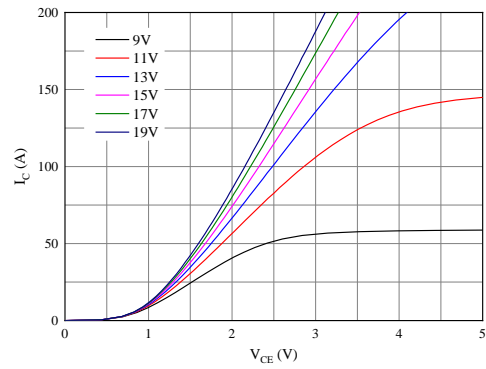

Fig 2. Typical output characteristics ($T_{vj}=150^\circ C$)

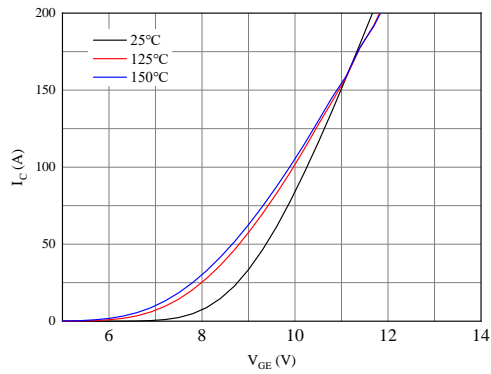

Fig 3. Typical transfer characteristic ($V_{CE}=20V$)

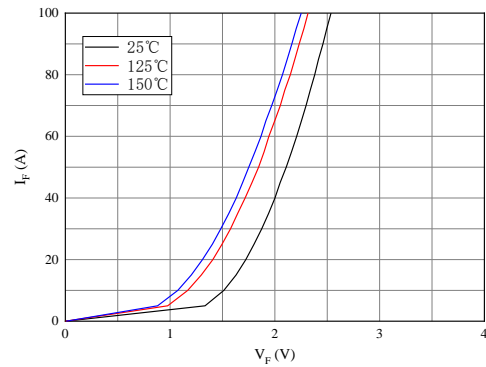

Fig 4. Forward characteristic of Diode

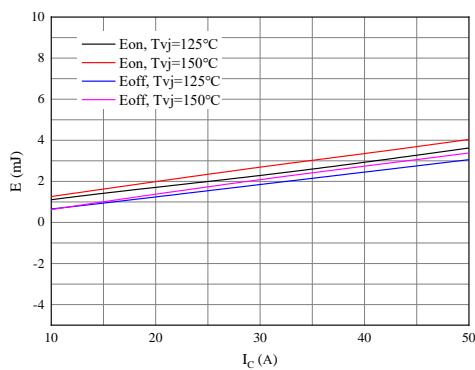

Fig 5. Switching losses of IGBT
 $V_{GE} = \pm 15V$, $R_{Gon} = 10\Omega$, $R_{Goff} = 10\Omega$, $V_{CE} = 600V$

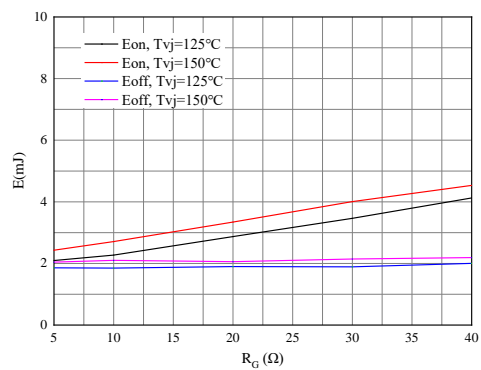

Fig 6. Switching losses of IGBT
 $V_{GE} = \pm 15V$, $I_C = 30A$, $V_{CE} = 600V$

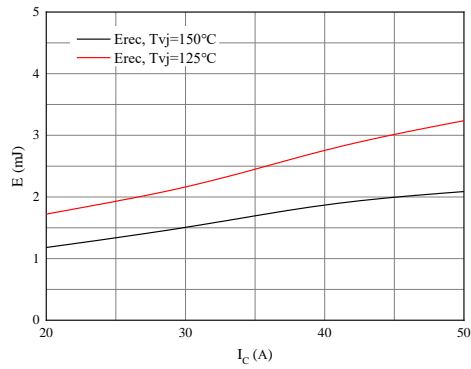

Fig 7. Switching losses of Diode
 $R_{Gon}=10\ \Omega$, $V_{CE}=600\text{V}$

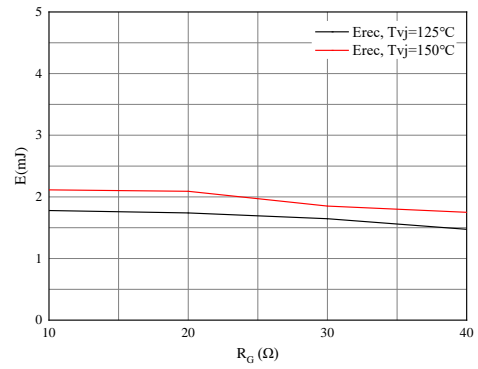

Fig 8. Switching losses of Diode
 $I_F=30\text{A}$, $V_{CE}=600\text{V}$

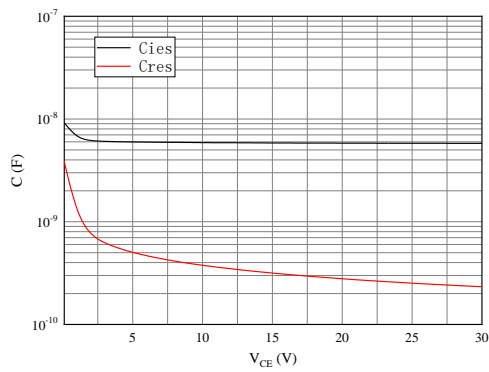
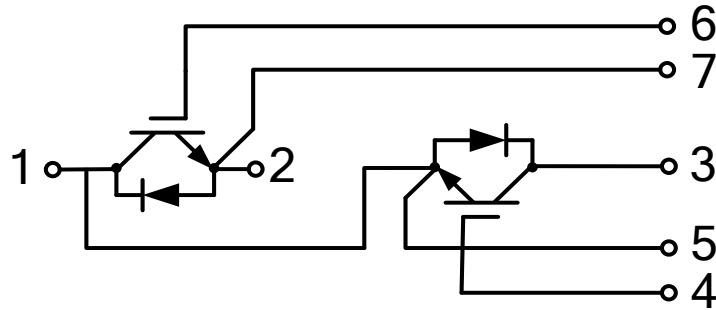

Fig 9. Capacitance characteristic

Circuit diagram



Package outlines

