

3-Level IGBT Module

$V_{CES} = 1200V$, $I_{C\ nom} = 300A / I_{CRM} = 600A$

Features :

- Trench /Field Stop process
- Low switching losses
- V_{cesat} has a positive temperature coefficient

Applications:

- 3-Level-Applications
- Energy storage inverter
- Annual Performance Factor
- UPS Systems

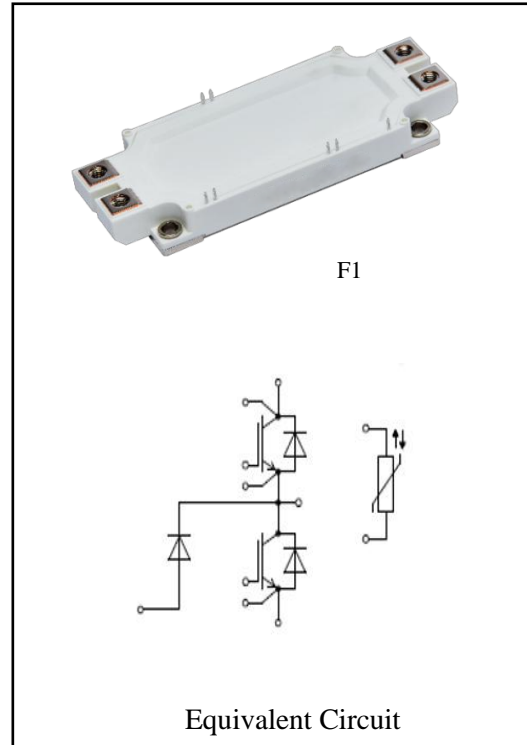

IGBT, Inverter

Maximum Ratings

Parameter	Conditions	Symbol	Value	Unit
Collector-Emitter voltage	$T_{vj} = 25^{\circ}C$	V_{CES}	1200	V
Continuous DC collector current	$T_C = 100^{\circ}C$, $T_{vj\ max} = 175^{\circ}C$	$I_{C\ nom}$	300	A
Repetitive peak collector current	$t_p = 1\ ms$	I_{CRM}	600	A
Total power dissipation	$T_C = 25^{\circ}C$, $T_{vj\ max} = 175^{\circ}C$	P_{tot}	580	W
Gate emitter voltage		V_{GE}	± 20	V

Characteristic Values

Parameter	Conditions	Symbol	Value			Unit	
			Min.	Typ.	Max.		
Collector-Emitter saturation voltage	$V_{GE}=15V, I_C=300A$	$T_{vj}=25^{\circ}C$		1.60	2.07	V	
	$V_{GE}=15V, I_C=300A$	$T_{vj}=125^{\circ}C$		1.80			
	$V_{GE}=15V, I_C=300A$	$T_{vj}=150^{\circ}C$		1.90			
Gate-Emitter threshold voltage	$I_C=11.5mA, V_{GE}=V_{CE}$	$T_{vj}=25^{\circ}C$	V_{GEth}	5.4	6.0	6.6	
Gate charge	$V_{GE}=-15V \dots +15V$		Q_G		3.14		μC
Internal gate resistor	$T_{vj}=25^{\circ}C$		R_{Gint}		0.53		Ω
Input capacitance	$f=100kHz, V_{CE}=25V, V_{GE}=0V$	$T_{vj}=25^{\circ}C$	C_{ies}		47.7		nF
Reverse transfer capacitance			C_{res}		0.43		
Collector-emitter cut-off current	$V_{CE}=1200V, V_{GE}=0V$	$T_{vj}=25^{\circ}C$	I_{CES}			2	mA
Gate-emitter leakage current	$V_{CE}=0V, V_{GE}=20V$	$T_{vj}=25^{\circ}C$	I_{GES}			200	nA
Turn-on delay time	$I_C=300A, V_{CE}=600V$ $V_{GE}=\pm 15V, R_G=2.5\Omega$ (inductive load)	$T_{vj}=25^{\circ}C$	t_{don}		109		
		$T_{vj}=125^{\circ}C$			110		
		$T_{vj}=150^{\circ}C$			111		
Rise time	$I_C=300A, V_{CE}=600V$ $V_{GE}=\pm 15V, R_G=2.5\Omega$ (inductive load)	$T_{vj}=25^{\circ}C$	t_r		103		
		$T_{vj}=125^{\circ}C$			111		
		$T_{vj}=150^{\circ}C$			112		
Turn-off delay time	$I_C=300A, V_{CE}=600V$ $V_{GE}=\pm 15V, R_G=2.5\Omega$ (inductive load)	$T_{vj}=25^{\circ}C$	t_{doff}		362		ns
		$T_{vj}=125^{\circ}C$			411		
		$T_{vj}=150^{\circ}C$			424		
Fall time	$I_C=300A, V_{CE}=600V$ $V_{GE}=\pm 15V, R_G=2.5\Omega$ (inductive load)	$T_{vj}=25^{\circ}C$	t_f		149		
		$T_{vj}=125^{\circ}C$			226		
		$T_{vj}=150^{\circ}C$			250		
Turn-on energy loss per pulse	$I_C=300A, V_{CE}=600V,$ $V_{GE}=\pm 15V, R_G=2.5\Omega,$ $di/dt=2170A/\mu s(T_{vj}=150^{\circ}C)$ (inductive load)	$T_{vj}=25^{\circ}C$	E_{on}		38.95		mJ
		$T_{vj}=125^{\circ}C$			60.43		
		$T_{vj}=150^{\circ}C$			67.16		
Turn-off energy loss per pulse	$I_C=300A, V_{CE}=600V,$ $V_{GE}=\pm 15V, R_G=2.5\Omega,$ $du/dt=4360V/\mu s(T_{vj}=150^{\circ}C)$ (inductive load)	$T_{vj}=25^{\circ}C$	E_{off}		22.23		mJ
		$T_{vj}=125^{\circ}C$			28.99		
		$T_{vj}=150^{\circ}C$			31.13		
SC data	$V_{GE} \leq 15V, V_{cc}=800V,$ $V_{CEmax}=V_{CES}-L_{sCE} \cdot di/dt$	$t_{pr} \leq 10\mu s, T_{vj}=150^{\circ}C$	I_{sc}		1300		A
Thermal resistance, junction to case	per IGBT		R_{thJC}			0.26	K/W
Temperature under switching conditions			$T_{vj op}$	-40		150	$^{\circ}C$

Diode, Inverter&3-Level

Maximum Ratings

Parameter	Conditions	Symbol	Value	Unit
Repetitive peak reverse voltage	$T_{vj}=25^{\circ}\text{C}$	V_{RRM}	1200	V
Continuous DC forward current		I_F	300	A
Repetitive peak forward current	$t_p=1\text{ms}$	I_{FRM}	600	A
I2t-value	$V_R=0\text{V}$, $t_p=10\text{ms}$, $T_{vj}=125^{\circ}\text{C}$	I2t	29000	A

Characteristic Values

Parameter	Conditions	Symbol	Value			Unit
			Min.	Typ.	Max.	
Forward voltage	$I_F=300\text{A}$, $V_{GE}=0\text{V}$ $T_{vj}=25^{\circ}\text{C}$	V_F		1.98	2.40	V
	$I_F=300\text{A}$, $V_{GE}=0\text{V}$ $T_{vj}=125^{\circ}\text{C}$			1.69		
	$I_F=300\text{A}$, $V_{GE}=0\text{V}$ $T_{vj}=150^{\circ}\text{C}$			1.61		
Peak reverse recovery current	$I_F=300\text{A}$, $V_R=600\text{V}$, $V_{GE}=-15\text{V}$, $R_G=2.5\Omega$, $-diF/dt=1690\text{ A/us}(T_{vj}=150^{\circ}\text{C})$ $T_{vj}=25^{\circ}\text{C}$	I_{RM}		70		A
	$T_{vj}=125^{\circ}\text{C}$			134		
	$T_{vj}=150^{\circ}\text{C}$			147		
Recovered charge	$I_F=300\text{A}$, $V_R=600\text{V}$ $V_{GE}=-15\text{V}$, $R_G=2.5\Omega$, $-diF/dt=1690\text{ A/us}(T_{vj}=150^{\circ}\text{C})$ $T_{vj}=25^{\circ}\text{C}$	Q_r		19.22		μC
	$T_{vj}=125^{\circ}\text{C}$			50.44		
	$T_{vj}=150^{\circ}\text{C}$			62.59		
Reverse recovered energy	$I_F=300\text{A}$, $V_R=600\text{V}$, $V_{GE}=-15\text{V}$, $R_G=2.5\Omega$, $-diF/dt=1690\text{ A/us}(T_{vj}=150^{\circ}\text{C})$ $T_{vj}=25^{\circ}\text{C}$	E_{rec}		6.59		mJ
	$T_{vj}=125^{\circ}\text{C}$			16.61		
	$T_{vj}=150^{\circ}\text{C}$			20.82		
Thermal resistance, junction to case	per diode	R_{thJC}			0.33	K/W
Temperature under switching conditions		$T_{vj\text{ op}}$	-40		150	$^{\circ}\text{C}$

NTC-Thermistor

Characteristic Values

Parameter	Conditions	Symbol	Value			Unit
			Min.	Typ.	Max.	
Rated resistances	$T_c=25^{\circ}\text{C}$, $\pm 5\%$	R_{25}		5.0		k Ω
B-value	$\pm 2\%$	$B_{25/50}$		3375		K

Module

Parameter	Conditions	Symbol	Value			Unit
Isolation test voltage	RMS, f=50Hz, t=1min	V _{ISOL}	2500			V
Internal isolation			Al ₂ O ₃			
Storage temperature		T _{stg}	-40		125	°C
Mounting torque for modul mounting		M	3.0		6.0	Nm
Terminal connection torque		M	3.0		6.0	Nm
Weight		W		340		g

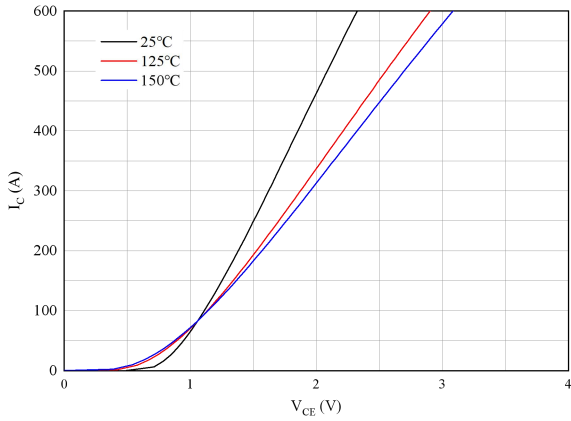

Fig 1. Typical output characteristics ($V_{GE}=15V$)

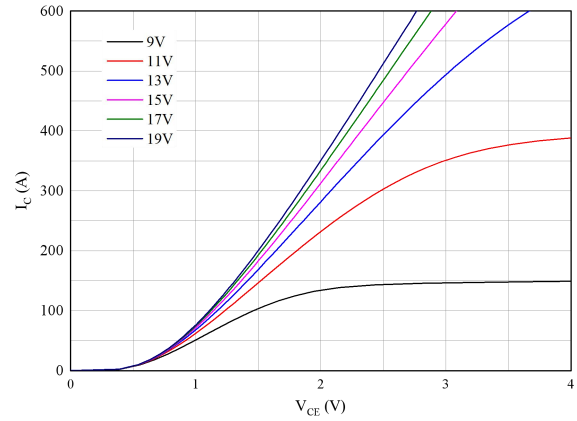

Fig 2. Typical output characteristics ($T_{vj}=150^{\circ}C$)

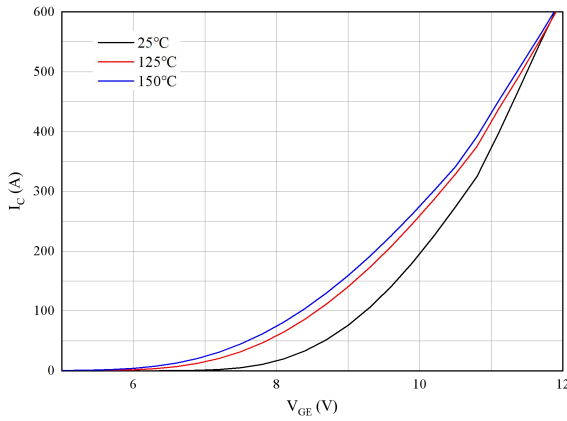

Fig 3. Typical transfer characteristic ($V_{CE}=20V$)

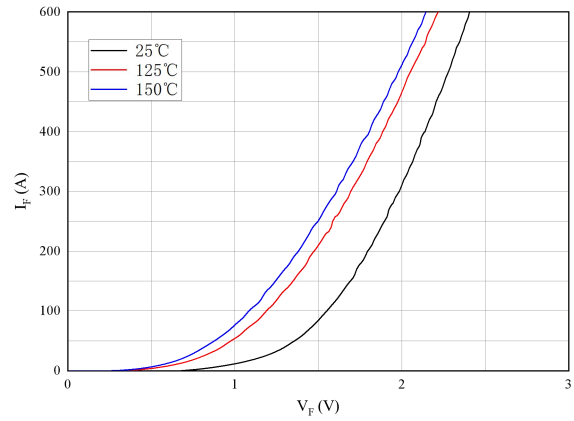

Fig 4. Forward characteristic of Diode

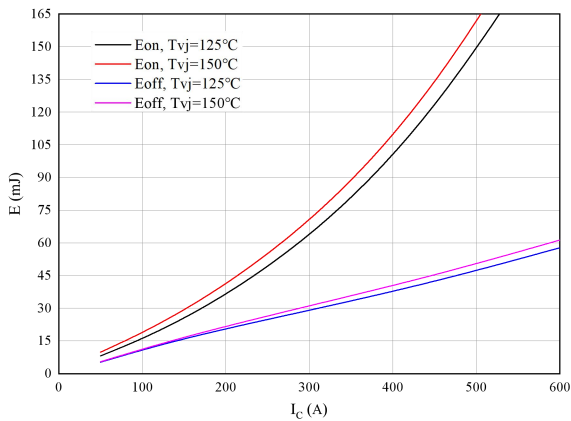

Fig 5. Switching losses of IGBT

$V_{GE}=\pm 15V$, $R_{Gon}=2.5\Omega$, $R_{Goff}=2.5\Omega$, $V_{CE}=600V$

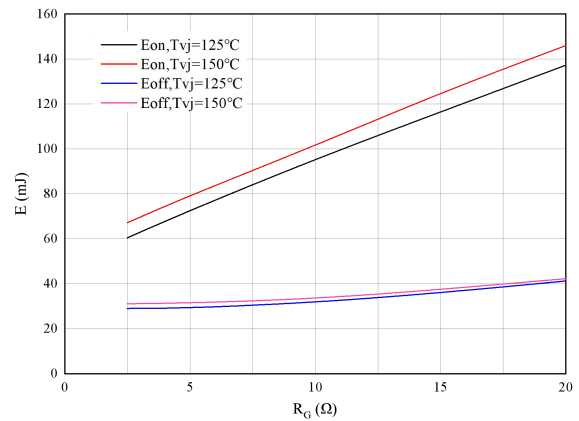

Fig 6. Switching losses of IGBT

$V_{GE}=\pm 15V$, $I_C=300A$, $V_{CE}=600V$

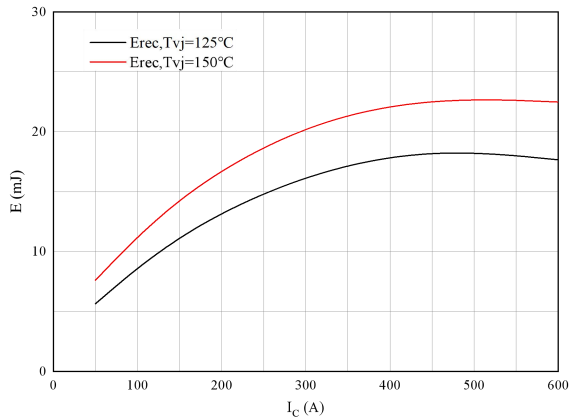

Fig 7. Switching losses of Diode
 $R_{Gon}=2.5\Omega, V_{GE}=600V$

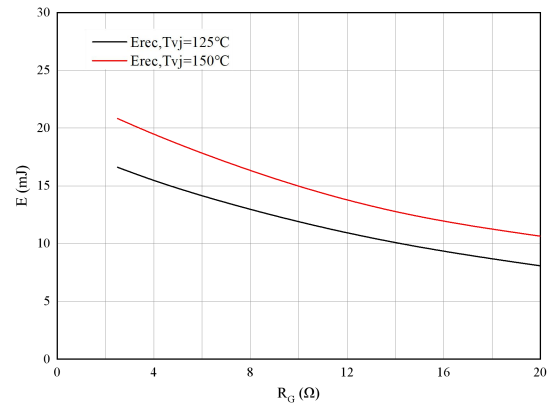

Fig 8. Switching losses of Diode
 $I_F=300A, V_{CE}=600V$

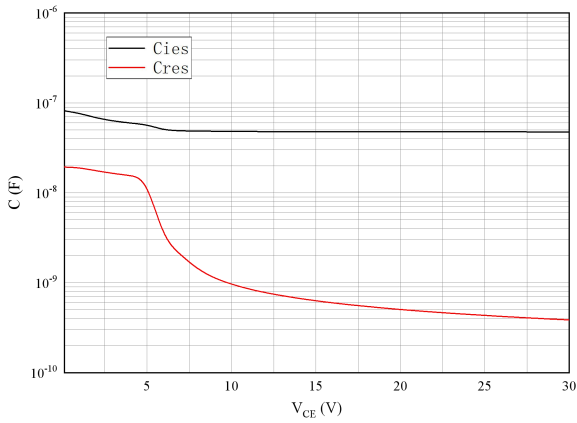

Fig 9. Capacitance characteristic

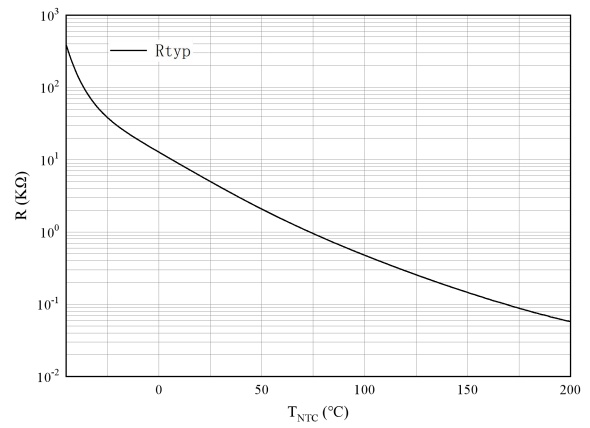

Fig 10. NTC-Thermistor-temperature characteristic

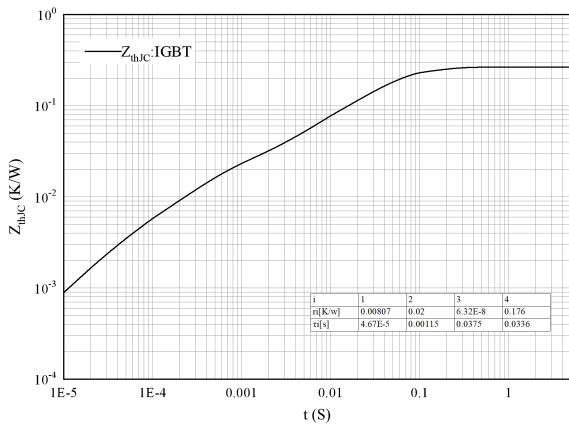

Fig 11. Transient thermal impedance IGBT, Inverter

$Z_{thJC}=f(t)$

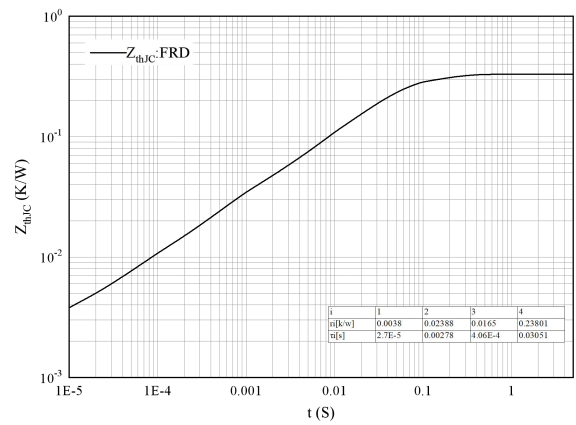
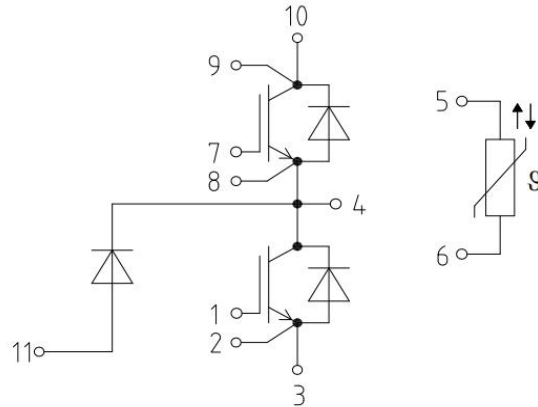

Fig 12. Transient thermal impedance FRD, Inverter

$Z_{thJC}=f(t)$

Circuit diagram



Package outlines

